

Revision			
Rev.	Description	Date	Approved
A-2		2015/1/22	RD

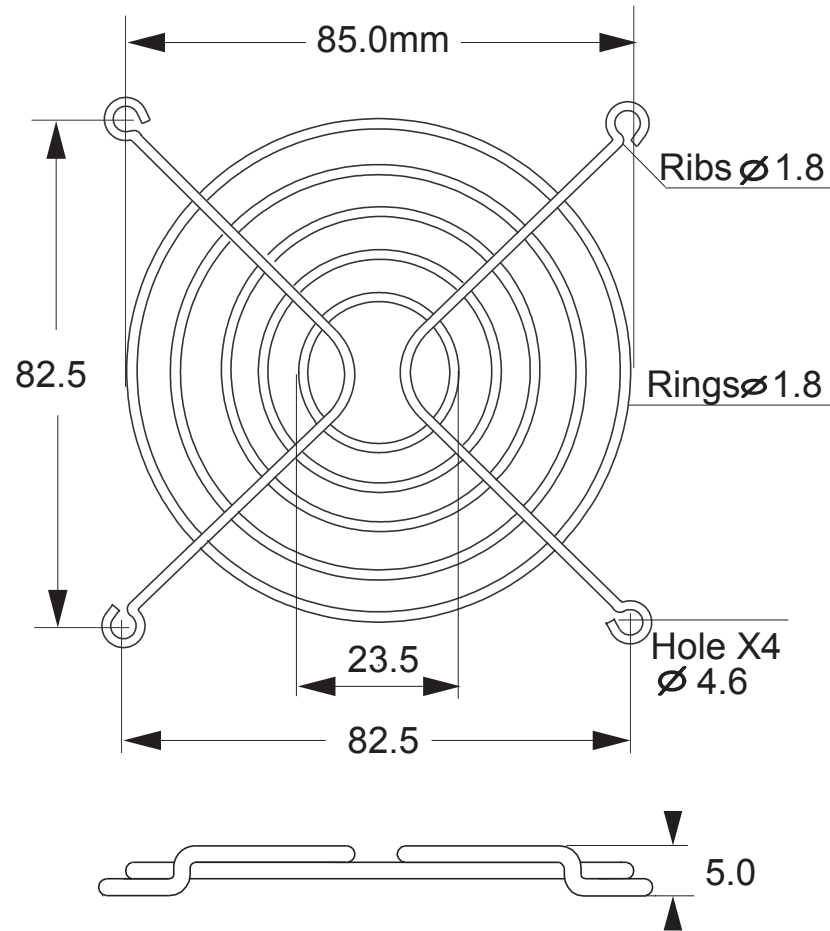

**Specifications:**

1. General tolerance unless noted is  $\pm 0.5\text{mm}$
2. Hole to Hole:  $82.5\text{mm} \pm 0.5\text{mm}$
3. Holes dia.:  $4.6\text{mm} \pm 0.2\text{mm}$
4. Outer ring dia.:  $85.0\text{mm} \pm 0.5\text{mm}$
5. Ring dia.:  $1.8\text{mm} \pm 0.1\text{mm}$
6. Rib dia.:  $1.8\text{mm} \pm 0.1\text{mm}$
7. Height.:  $5.0\text{mm} \pm 0.2\text{mm}$
8. Stagger welds: 5 rings

**Material:**

- Rings & Ribs Steel wire BLI-195(C1008)
- Surface Treating  
Nickled-chrome electro plating surface, bright color  
(Black color & other platings are available on request)
- Comply with the limits as set by RoHS / SVHC
- Weld Joins Contact Strength  
Spot welding Points to withstand min. 220lbs(100Kgs.)
- Weight: 21.8Gm

**Mates with:**

- SD9225PT, SD938, S92AP, S938AP, M938AP series cooling fan

 **Sinwan Electric Industries Co., Ltd.**

Part Number:

**G92-13**

Description:

Metal Fan Guard For 92mm (3.62") Fan