

Revision			
Rev.	Description	Date	Approved
A-2		2014/12/17	RD

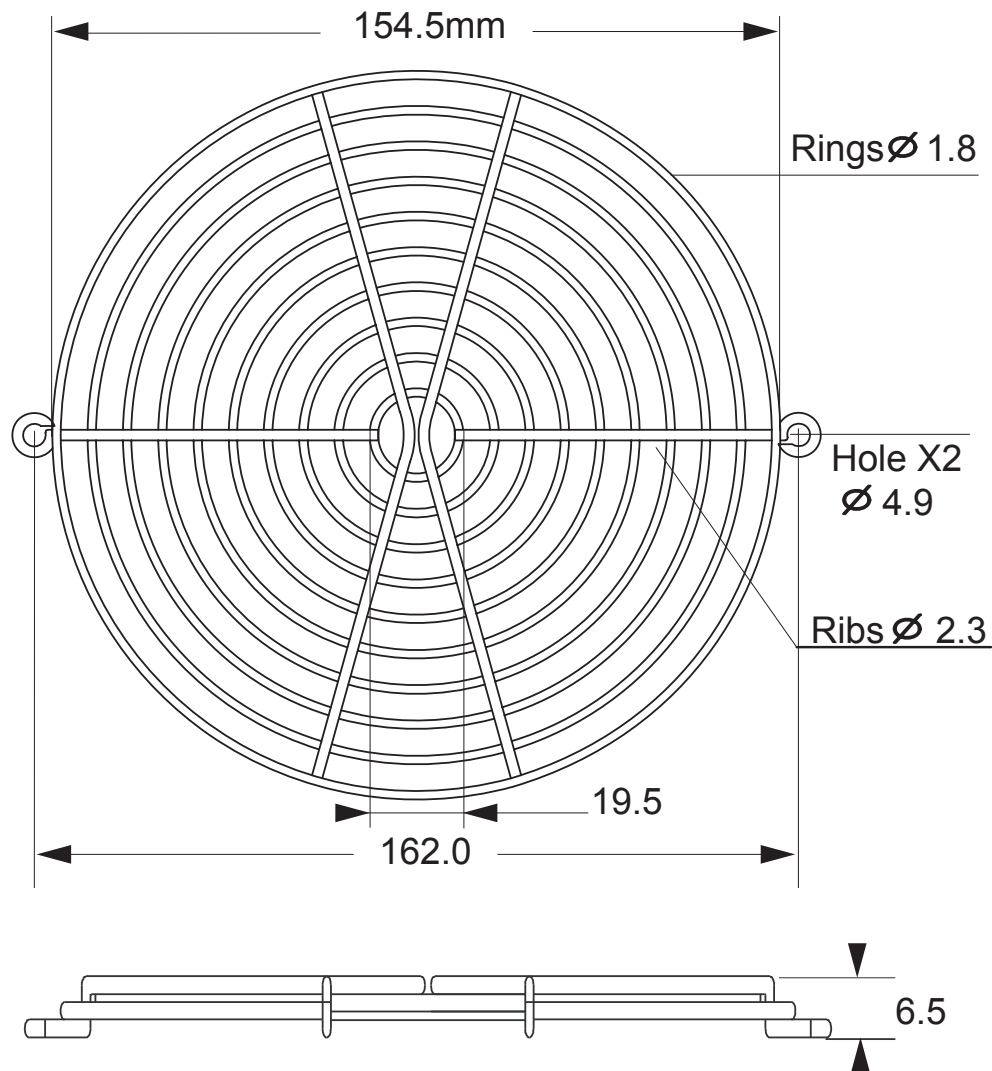

Specifications:

1. General tolerance unless noted is $\pm 0.5\text{mm}$
2. Hole to Hole: $162.0\text{mm} \pm 0.5\text{mm}$
3. Holes dia.: $4.9\text{mm} \pm 0.2\text{mm}$
4. Outer ring dia.: $154.5\text{mm} \pm 0.5\text{mm}$
5. Ring dia.: $1.8\text{mm} \pm 0.1\text{mm}$
6. Rib dia.: $2.3\text{mm} \pm 0.1\text{mm}$
7. Height: $6.5\text{mm} \pm 0.2\text{mm}$
8. Stagger welds: 10 rings

Material:

- Rings & Ribs Steel wire BLI-195(C1008)
- Surface Treating
Nickled-chrome electro plating surface, bright color (Black color & other platings are available on request)
- Comply with the limits as set by RoHS / SVHC
- Weld Joins Contact Strength
Spot welding Points to withstand min. 220lbs(100Kgs.)
- Weight: 68.0Gm

Mates with:

- SD173AP, SD175SAP, SD175EAP, SD175RAP, S150AP, S162AP, S162SAP, S172SAP, S172RAP, M150AP, M172SAP, M172EAP, M172RAP, MD173AP, MD175SAP, MD175EAP, MD175RAP series cooling fan

 **Sinwan Electric Industries Co., Ltd.**

Part Number:

G172-10HA

Description:

Metal Fan Guard For 172mm (6") Fan